



## INSTRUCTIONS REGARDING DELIVERY OF GOODS TO THE KDG SITES ELBIGENALP, STANZACH, FÜSSEN

### Contents

0. Preliminary remarks	1
1. Delivery times	1
2. Accompanying documents	2
3. Pallet and package labelling	2
4. Acceptance of goods	3
5. Returned goods	3
6. Palleting	3
7. Road access to company premises	4
8. Recyclability of packaging material	4
9. Infringements procedure	4
10. Annexes	4

## 0. Preliminary remarks

The following instructions regarding the acceptance of goods to the kdg sites at Elbigenalp (kdg opticomp), Stanzach (kdg medialog) and Füssen (kdg medialog) are an appendix to our General Purchasing Conditions and apply without exception to each delivery of goods. We should like to take this opportunity to remind our business partners politely once more that we attach great importance to the correct and proper delivery of goods. You are therefore kindly requested to ensure that your freight forwarder is aware of these instructions and follows all of them.

## 1. Delivery times

Locations	ELBIGENALP (kdg opticomp)	STANZACH (kdg medialog)	FÜSSEN (kdg medialog)
Address	Am kdg campus, Dorf 91 A-6652 Elbigenalp	Blockau 61 A-6642 Stanzach	Hiebelerstraße 45a D-87629 Füssen
Delivery times for <10 Pal Mon - Fri	8:00 – 16:00	8:00 – 12:00 12:30 – 16:00	8:00 – 12:00 12:30 – 16:00 (Fri 15:00)
Delivery times for >10 Pal Mon - Fri	8:00 – 14:00	T +43 5634 500 272	T +43 5634 500 272

Please note: For deliveries > 10 pallets the delivery period in Elbigenalp ends two hours prior to the times indicated above. In Stanzach and Füssen every delivery has to be advised by 3 p.m. on the day before. Later deliveries can only be accepted after prior consultation.

In general, for organisational and technical reasons, deliveries of goods cannot be accepted before the agreed delivery time or before the delivery time you have confirmed. Deliveries made before the confirmed delivery time will only be accepted in exceptional cases and are always subject to prior agreement being obtained with your kdg point of contact.



Delivery times must be confirmed without exception using the confirmation of order form. In order for us to ensure smooth production planning and throughput of goods it is absolutely vital that agreed delivery times are maintained. Consequently, confirmed delivery times are binding for us, even when the place of delivery should remain open at the time of placing the order. In general we reserve the right to change details of the address or place of delivery up to 48 hours before the agreed delivery time. In certain instances this may also occur up to 24 hours before the agreed time of delivery. For complete truck loads you are kindly asked to advise your kdg point of contact of the time of delivery two hours prior to the expected time of delivery.

## 2. Accompanying documents

Our incoming goods unit is under orders only to accept consignments with correctly issued delivery notes. The delivery note accompanying your consignment must contain the following details (items):

- delivery note number
- name and address of sender
- name of freight forwarder
- type of consignment
- date of consignment
- designation of article ordered (description, code)
- place of manufacture
- our order number
- quantity ordered
- weight
- number of pallets and packages
- reference to any hazardous materials
- unloading point
- kdg point of contact

In the event the consignment consists of more than one package, please ensure that the delivery note is attached in a prominent position on the unused part of the pallet. This pallet (or unit of freight) should display appropriate indications for our incoming goods unit.

## 3. Pallet and package labelling

All pallets and units of freight for delivery to kdg should display bar code labels. The contents and form of the labels should be based on the following sample label.





Fig. 1: Sample of a bar code label required for shipments to kdg

The labels should be attached prominently on the pallets and packages. A detailed description of the bar code structure and label is given in the annexes (10.1).

## 4. Acceptance of goods

Acceptance of goods in our establishment is always 'conditional' and subject to the General Purchasing Terms of kdg, with particular reference to items 13 (quality), 14 (defects, warranties) and 15 (product liability).

## 5. Returned goods

For returned goods you require special accompanying documents which you should request at an early stage from your kdg point of contact. You are politely reminded that we will only accept returned goods with correct accompanying documents. In general, delivery of returned goods shall take place carriage paid.

## 6. Palleting

The following palleting specifications must be met for consignments to the kdg sites of Elbigenalp, Stanzach and Füssen:

- we accept either *non-reusable pallets measuring 120 x 80 cm, 80 x 60 cm*
- *or EURO pallets in good condition, but no PKP pallets*
- *reusable pallets must meet the quality requirements listed at [www.epal-pallets.org](http://www.epal-pallets.org)*
- *pallets with a board on the front side cannot be accepted*
- *the minimum height for fork-lift trucks is 100 mm (free space for flt)*
- *the maximum dimensions of each pallet are (l x w x h): 120 x 80 x 200 cm,*
- *for cardboard packaging the maximum pallet height is 185 cm for CD and DVD packaging the maximum pallet height is 195 cm*
- *packaging material (e.g. boxes, trays) must be excise sealed and under no circumstances palleted into covering boxes*
- *loose articles should be delivered in covering boxes*
- *stacked or excise sealed articles must be protected along the edges*
- *packaging bands must be made of plastic*
- *please use intermediate layers of cardboard / foil to prevent goods from sliding*
- *in addition, each pallet must be adequately secured against dampness and sliding*

*Please note:*

- *freight must not protrude from the pallets*
- *as a general rule, pallets must not be stacked*
- *we do not accept mixed palleting*
- *you should inform us in good time of the unloading equipment required for the delivery (e.g. fork-lift trucks up to 2 tons, crane, etc.)*

The following instructions also apply in the case of printed materials:

- *Printed materials should always be stacked according to the spiral principle (see 10.2 'CD cardboard box for printed matter' and 10.3 'DVD cardboard box for printed matter' in the annexes)*



- CD printed materials should be delivered upright in the box and DVD printed materials should be delivered flat in the box with uniform alignment in both cases
- Please also refer to our specifications manual on the Internet

## 7. Road access to company premises

see Annex 10.4 and 10.5 Road access for delivery lorries and vans

## 8. Recyclability of packaging materials

In general use of non-recyclable packaging should be kept to a minimum. Environmentally friendly and reusable materials should be used instead. Material combinations such as staples and nails in wood must be able to be easily separated after use. Package labelling should not impair recyclability. In general you are not entitled to request the exchange or return of non-recyclable packaging.

## 9. Infringements procedure

Infringements against the delivery instructions listed in points 1 - 8 above will incur the following handling charges for which you are liable. Please note that these costs may vary according to particular market conditions.

Repacking due to excess length, defective condition, defective stability, incorrect height, missing intermediate layers, etc.

wrapping with stretch film

Labelling

		EUR	20.00/pallet	Additional
	EUR	10.00/pallet		
		EUR	0.30/label	

Any other additional costs will be charged on the basis of expense incurred and current purchase prices.

## 10. Annexes

*Annex 10.1. Specifications for barcode structure and label*

*Annex 10.2. CD cardboard box for printed matter*

*Annex 10.3. DVD cardboard box for printed matter*

*Annex 10.4. Road access for delivery lorries and vans in Elbigentalp*

*Annex 10.5. Road access for delivery lorries and vans in Stanzach and Füssen*

### Annex 10.1. Specifications for bar code structure and label



#### Specifications for bar code structure

- Bar code: **CODE 128 (B)**
- Structure: **\$ NUMBER OF ITEMS \* CODE + PRODUCTION NUMBER** - with "\$" and "\*" and "+" required separators; e.g.: \$ 20 \* 30006 + 812.232
- Number of items: refers to items contained in the relevant unit of packaging
- Code: designates the article (according to the order)
- Production number: the kdg production number (between 7 and 12 digits)

#### Specifications for the bar code label

The bar code label should contain the following information:

- the title of the production number or the name of the article (according to the order)
- your company name
- possible kind of sound carrier: DVD, CD, MC, LP or CDR
- the date (of the label issue)

In general these labels can be created without having to display the number of items or production number (in the case of jewel boxes or film for example). Please note that the production number must always be displayed for order-related articles (e.g. printed matter). Each item of information can be positioned as you wish. The important thing to remember is that they must make use of the separators above.

### Annex 10.2. CD cardboard box for printed matter

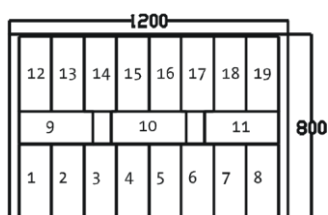

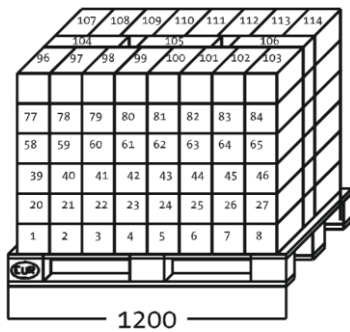

**Cardboard**  
Dimension: 320 x 140 x 130 (l x w x h)

**Annex 10.3. DVD cardboard box for printed matter**

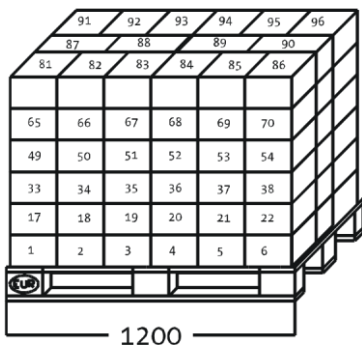
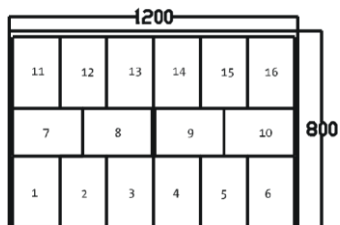

**Karton**  
Maße: 290 x 195 x 130 (L x B x H)



**Annex 10.4. Road access for delivery lorries and vans in Elbigenalp**

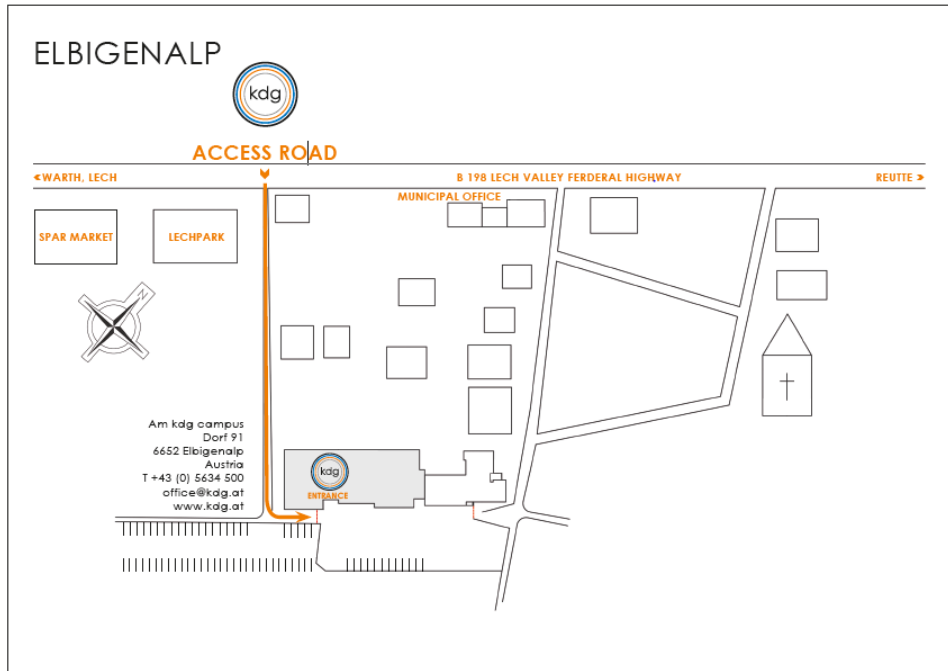

**Annex 10.5. Road access for delivery lorries and vans in Stanzach and Füssen**

